

# Four-Wheel Drive Rough Terrain Forklift

with capacities of 2,500 to 3,500kg



*The World of Hangcha*  
SINCE 1956

  
**HANGCHA**

## CONCEPT

The multipurpose concept refers to the capability of the forklift truck to work in many different areas, with a great performance no matter how hard the conditions are.

We studied all the specifications of the best forklifts in the world, specialized in industrial and rough terrain types, determining the characteristics that makes a forklift work well in an industrial environment. After that, we combined such information, to prepare the basis of the design of our product.



## INTRODUCTION

Hangcha 2.5~3.5t 4W rough terrain forklifts is a tough, compact forklift with a two-wheel drive system. It is based on two-wheel drive rough terrain forklift, adopt CUMMINS and YANMAR diesel engine. It is world renowned for superior performance, economy and longevity.



# 6 reasons

choose

Four-Wheel Drive

Rough Terrain Forklift

- ▶ **RELIABILITY**
- ▶ **PRODUCTIVITY**
- ▶ **ENVIRONMENTAL FRIENDLINESS**
- ▶ **COMFORTABLE OPERATION**
- ▶ **EASY MAINTENANCE**
- ▶ **HIGH PERFORMANCE**



# RELIABILITY

The full-floating hydraulic transmission gearbox, with 2WD and 4WD switch function, can provide higher running speed and stronger gradeability;

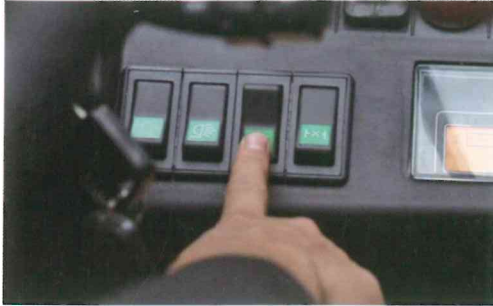

Higher specification fork mounting level-3B, more weight can be loaded.

## Wide-base deep tread tyres

The drive axle is equipped with wide-base deep tread tyres, wet brake, differential mechanism with electronic lock, as well as reinforced steering drive axle, and can better adapt to special working conditions.

Front tyre:14-17.5

Rear tyre:10.0/75-15.3





*Oscillating steer axle allows either wheel to step over obstacles keeping the truck and load level.*

Dual air filter, extra capacity combined radiator with serpentine wave and optimized heat dissipation channel enhance the heat dissipation capability to keep engine reliability even in heavy-duty applications.



The differential is specifically designed for rough terrain and features manual differential lock providing ultimate traction during inclement weather conditions and rough operating surfaces, it differential lock prevents power loose when one wheel spins.



## PRODUCTIVITY

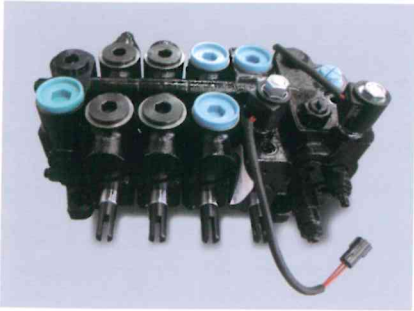

The new Dynamic load sensing hydraulic steering system contributes to reduce loss of hydraulic and improve energy efficiency.



The new efficiency lighting system employs LED illuminant and new type reflector to reduce energy consumption, improve significantly illumination performance and prolong work time.

## COMFORTABLE OPERATION

*In developing the rough terrain forklift, comfort and easy operation is always considered, for example, improved vibrating levels, compound engine damper and full floating seat and cabin are all applied.*

*Comfortable also contribute to increased productivity and reduced the noise.*



# ENVIRONMENTAL FRIENDLINESS

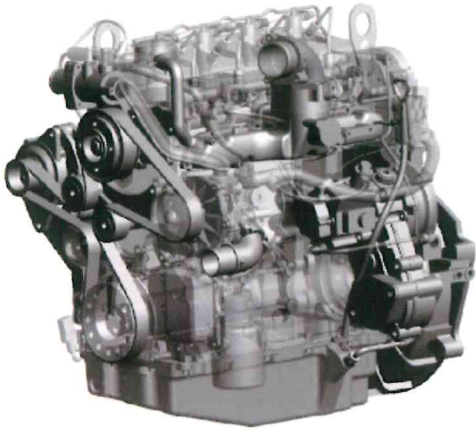

CUMMINS QSF2.8

A lineup of powerful and clean engines and environment friendly materials help to reduce the output of undesirable substances over the lifetime of the truck, while creating a cleaner work environment.

Each model employs a specially developed engine for the optimum balance of power and superior environmental performance, the truck is in compliance with EU III and EAP III control regulation.

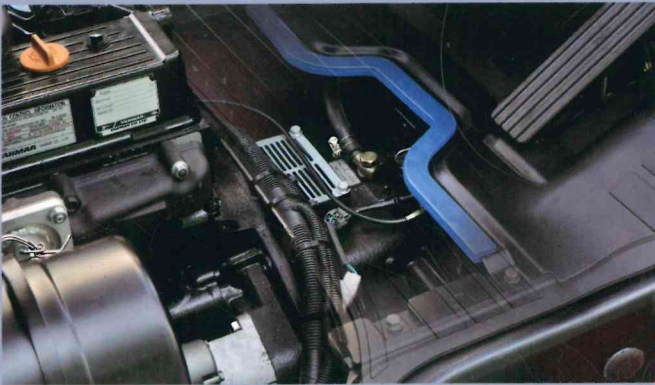

1. In addition to rubber damper between frames and steering axle, compound engine damper and full floating power train achieve flexible connection between frames and driving system, as a result, traveling vibrations and vibrations from the driving system are significantly reduced.



2. The extra foot space is provided to reduce operator fatigue significantly, non-slip step makes getting in and out easy and safe. The new designed steering wheel, new brake system and the easy-to-operate levers provide total handling operation.



3. Optimized designing structure to offer a good visibility.



4. The new design mast provides broad forward visibility due to the longer distance between inside mast.

Simple/  
Solid/  
Smart





# EASY MAINTENANCE



Newly-developed LCD instrument has more comprehensive functions and more stable performance and entirely displays the full truck state, fault code and other important information, which can make the operator more intuitively and conveniently have a better knowledge of truck state and make the maintenance conveniently.



Adoption of new generation integrated electric box makes maintenance and repair convenient, layout becomes more reasonable and with better water-proof performance.



The easy-to-open hook provides quick access to the engine compartment.



Wet brake offers maximum service life for your brake system.

- / The cover on the Panel can be lifted up simply to check the brake fluid.
- / The two-piece design makes the floorboard easy to lift and remove for access to the power train.
- / The fasteners of the radiator cover can be turned easily by hand to enable quick inspections or servicing.



# FOUR-WHEEL DRIVE ROUGH TERRAIN FORKLIFT

## HIGH PERFORMANCE



### *Maneuverability*

The distance to ground is 270mm for 3.0t, it offers greater maneuverability and keep the truck moving in the roughest of applications, and yet we keep a very low center of gravity, by using a distributed weight in the forklift, giving it an excellent stability.

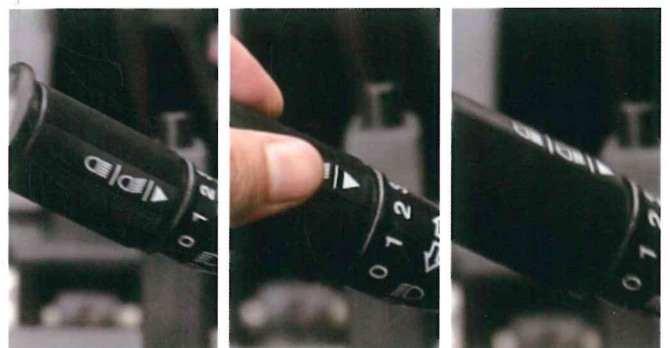

### *Three forward gears*

Suspension hydraulic transmission with three forward gears, top speed reach 26km/h.



#### YANMAR 4TNE98

Model: 4TNE98 (EuIII/EPAIII)  
 Rated output: 42.1kw/2300rpm  
 Rated torque: 196N.m/1700rpm  
 NO. of cylinder: 4  
 Displacement: 3.319L



The transmission system gets the maximum performance from the engine without reaching high revolutions, which permits fuel saving, noise level reduction and engine life increase.

### Standard specification

- / Suspension transmission
- / Differential lock
- / 2-wheel drive, 4-wheel drive system
- / Suspension seat
- / Return oil filter
- / Big capacity aluminum radiator
- / Air filter
- / Rear working light
- / Warning lamp
- / Cover for tilt cylinder
- / Reversing assist grip
- / Wider fork carriage
- / Wider load backrest
- / LED light

### Options

- / Cabin
- / Heater
- / Front window
- / L/R mirror
- / Extinguisher
- / Customer painting
- / OPS system
- / Sparkle arrester
- / Purified exhaust system
- / Auxiliary hydraulic valve
- / Front working light
- / Triplex wide view free-lift mast
- / Special forks
- / Weigher system
- / Attachments
- / Net cover of radiator

# FOUR-WHEEL DRIVE ROUGH TERRAIN FORKLIFT SPECIFICATION:

Distinguishing mark	HANGCHA GROUP CO.,LTD.							
		CPCD25-XW33C-RT4	CPCD30-XW33C-RT4	CPCD35-XW33C-RT4	CPCD25-XW43C-RT4	CPCD30-XW43C-RT4		
1.1	Manufacturer							
1.2	Manufacturer's type designation							
1.3	Drive: electric (battery or mains), diesel, petrol, fuel gas	Diesel	Diesel	Diesel	Diesel	Diesel		
1.4	Operator type: hand, pedestrian, standing, seated, order-picker	Seated	Seated	Seated	Seated	Seated		
1.5	Rated capacity/rated load	Q (kg)	2500	3000	3500	3000		
1.6	Load centre distance	c (mm)	500	500	500	500		
1.8	Load distance, centre of drive axle to fork	x (mm)	585	600	600	585		
1.9	Wheelbase	y (mm)	1880	1880	1880	1880		
Weight	2.1	Service Weight	kg	4850	5340	5600	4850	5340
	2.2	Axle loading, laden front/rear	kg	6190/1160	7200/1140	7900/1200	6190/1160	7200/1140
	2.3	Axle loading, unladen front/rear	kg	2130/2720	2340/3000	2300/3300	2130/2720	2340/3000
Tyres, chassis	3.1	Tyres: solid rubber, superelastic, pneumatic, polyurethane	Pneumatic					
	3.2	Tyre size, front	12-16.5-14PR	14-17.5-14PR	14-17.5-14PR	12-16.5-14PR	14-17.5-14PR	
	3.3	Tyre size, rear	10.0/75-15.3-14PR	10.0/75-15.3-14PR	10.0/75-15.3-14PR	10.0/75-15.3-14PR	10.0/75-15.3-14PR	
	3.5	Wheels, number front / rear (x = driven wheels)	2x/2x					
	3.6	Tread, front	b10 (mm)	1250	1250	1250	1250	
	3.7	Tread, rear	b11 (mm)	1190	1190	1190	1190	
	Dimensions	4.1	Tilt of mast/fork carriage forward/backward	a/β(°)	10/12	10/12	10/12	10/12
4.2		Height, mast lowered	h1 (mm)	2215	2350	2350	2215	2350
4.3		Free lift	h2 (mm)	140	145	145	140	145
4.4		Lift	h3 (mm)	3000	3000	3000	3000	3000
4.5		Height, mast extended	h4 (mm)	4122	4142	4142	4122	4142
4.7		Height of overhead guard (cabin)	h6 (mm)	2390	2420	2420	2390	2420
4.19		Overall length	l1 (mm)	4305	4320	4320	4305	4320
4.20		Length to face of forks	l2 (mm)	3085	3100	3100	3085	3100
4.21		Overall width	b1 (mm)	1557	1599	1599	1557	1599
4.22		Fork dimensions ISO 2331	s/e/l (mm)	40×122×1220	50×122×1220	50×122×1220	50×122×1220	50×122×1220
4.23		Fork carriage DIN 15 173 --- ISO 2328, class/type A,B		B	B	B	B	B
4.24		Fork-carriage width	b3 (mm)	1150	1150	1150	1150	1150
4.25		Distance between fork-arms	bs (mm)	290-1150	290-1150	290-1150	290-1150	290-1150
4.31		Ground clearance, laden, below mast	m1 (mm)	240	270	270	240	270
4.32		Ground clearance, centre of wheelbase	m2 (mm)	260	290	290	260	290
4.34	Aisle width	Ast (mm)	5305	5320	5320	5305	5320	
4.35	Turning radius	wa (mm)	3300	3300	3300	3300	3300	
Performance data	5.1	Travel speed, laden/unladen	km/h	24/26	24/26	24/26	23/25	23/25
	5.2	Lift speed, laden	m/s	0.62/0.64	0.49/0.51	0.43/0.51	0.62/0.64	0.49/0.51
	5.3	Lowering speed, laden	m/s	0.5/0.44	0.5/0.45	0.5/0.45	0.5/0.44	0.5/0.45
	5.5	Drawbar pull, laden	N	40000	45000	45000	40000	43000
	5.7	Gradeability, laden	%	58	55	52	52	46
	5.10	Service brake		Hydraulic	Hydraulic	Hydraulic	Hydraulic	Hydraulic
Combustion-engine		Parking brake		Mechanical	Mechanical	Mechanical	Mechanical	Mechanical
	7.1	Engine manufacturer/type		YANMAR 4TNE98	YANMAR 4TNE98	YANMAR 4TNE98	CUMMINS QSF2.8t3NA49	
	7.2	Engine power according to DIN ISO 1585	kw/r/min	42.1/2300	42.1/2300	42.1/2300	36.5/2500	
	7.3	Rated speed	N·m/r/min	196/1700	196/1700	196/1700	186/1500	
	7.4	Number of cylinders/displacement	(-)/ (cm <sup>3</sup> )	4/3319	4/3319	4/3319	4/2800	
	7.10	Battery voltage/nominal capacity	V/Ah	12/90	12/90	12/90	12/90	
Addition data	10.3	Hydraulic Tank - capacity (drain & refill)	liter	60	60	60	60	
	10.4	Fuel tank capacity	liter	60	60	60	60	

## 2.5-3.5t Mast:(pneumatic)

Type	Model	Max.fork height	Overall height						Free lift				Front Overhang		Tilt range	
			Lowered (mm)		Extended				Without backrest (mm)		With backrest (mm)		(mm)		FWD (°)	BWD (°)
			2.5t	3/3.5t	Without backrest (mm)	With backrest (mm)	Without backrest (mm)	With backrest (mm)	2.5t	3/3.5t	2.5t	3/3.5t				
Wide view mast	RTE25/35M300	3000	2215	2350	3782	3993	4122	4142	140	145	140	145	585	600	10	12
	RTE25/35M330	3300	2365	2500	4082	4293	4422	4442	140	145	140	145	585	600	10	12
	RTE25/35M350	3500	2465	2600	4282	4493	4622	4642	140	145	140	145	585	600	10	12
	RTE25/35M370	3700	2615	2700	4482	4693	4822	4842	140	145	140	145	585	600	10	12
	RTE25/35M400	4000	2815	2950	4782	4993	5122	5142	140	145	140	145	585	600	10	12
Wide view full free triplex mast	RTE25/35N400	4000	2115	2300	4860	5025	5122	5269	1255	1275	993	1031	603	618	10	12
	RTE25/35N430	4300	2215	2400	5160	5325	5422	5569	1355	1375	1093	1131	603	618	10	12
	RTE25/35N450	4500	2265	2450	5360	5525	5622	5769	1405	1425	1143	1181	603	618	10	12
	RTE25/35N470	4700	2365	2550	5560	5725	5822	5969	1505	1525	1243	1281	603	618	10	12
	RTE25/35N500	5000	2515	2700	5860	6025	6122	6269	1655	1675	1393	1431	603	618	6	6
	RTE25/35N550	5500	2715	2900	6360	6525	6622	6769	1855	1875	1593	1631	603	618	6	6
	RTE25/35N600	6000	2965	3150	6860	7025	7122	7269	2105	2125	1843	1881	603	618	6	6

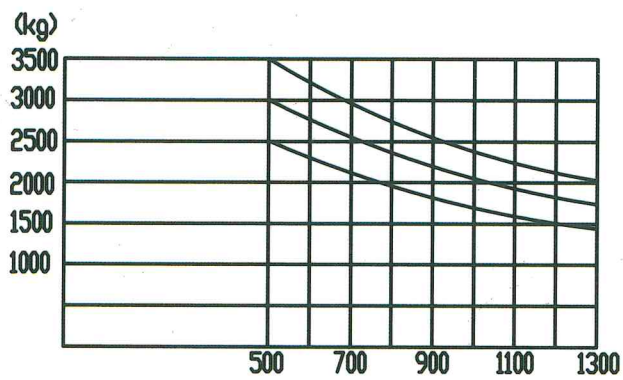
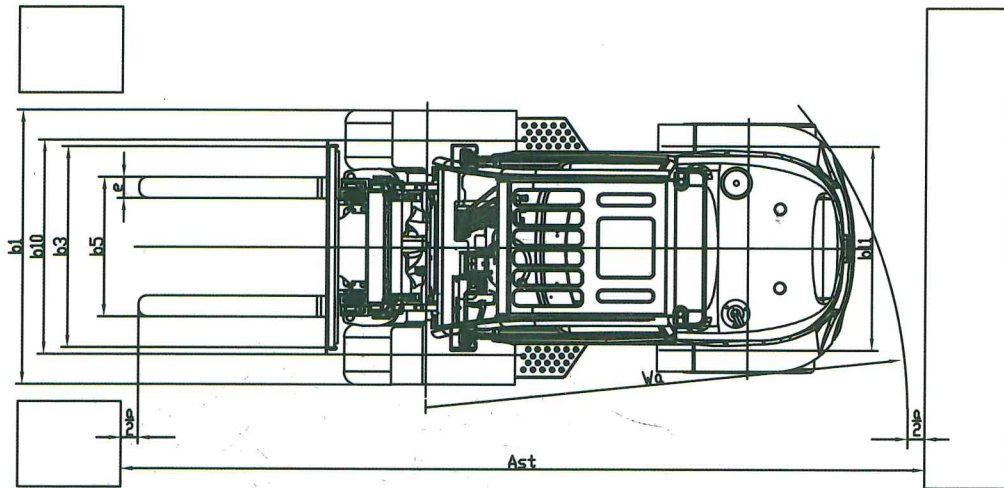
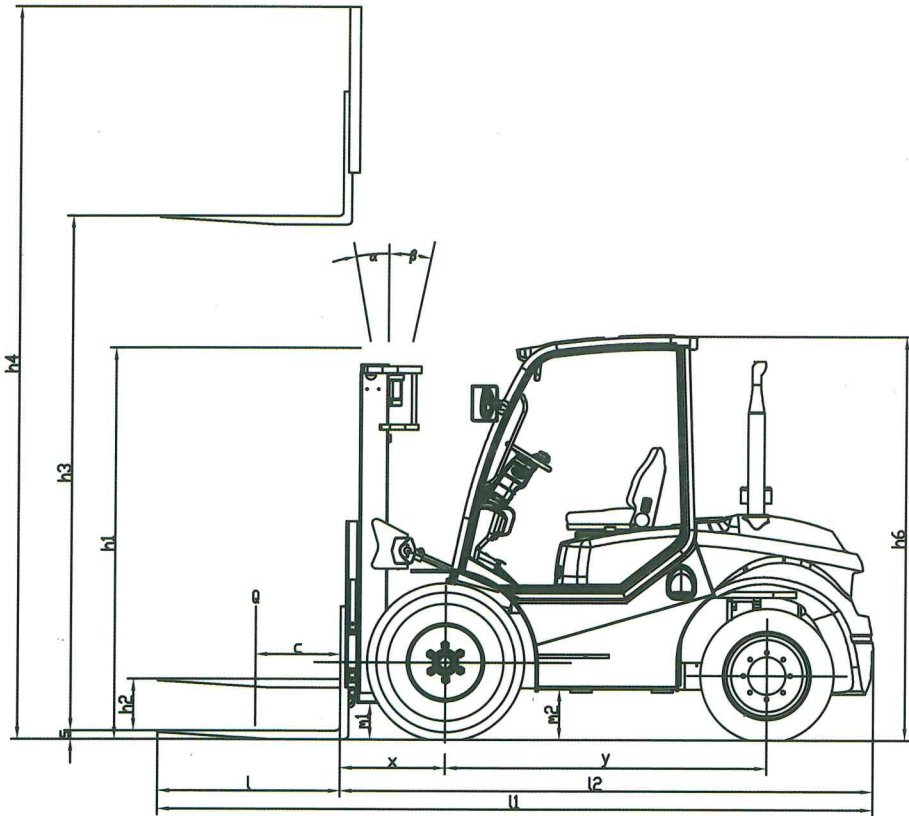



**ZHEJIANG HANGCHA IMP. & EXP. CO., LTD.**

**Factory site:** No. 88, Donghuan Rd., Lin'an  
Economic Development Zone, Zhejiang,  
China (311305)

Tel: +86-571-88926735 88926755  
Fax: +86-571-88132890 88926789

[sales@hcforklift.com](mailto:sales@hcforklift.com)  
[www.hcforklift.com](http://www.hcforklift.com)



HANGCHA GROUP CO., LTD. reserves the right to make any changes without notice concerning colors, equipment, or specifications detailed in this brochure, or to discontinue individual models. The colors of trucks, delivered may differ slightly from those in brochures.